

# Four-bolt flanged housing units

Flake graphite cast iron housings

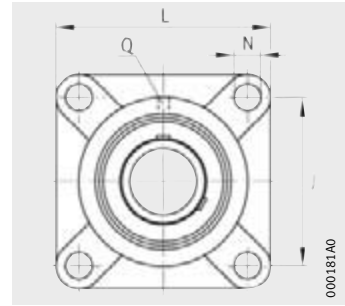

UCF

**Dimension table** · Dimensions in mm

Designation		Housing	Bearing	Mass m ≈kg	Dimensions		
Unit					d	J	L
mm	inch						
<b>UCF204</b>	–	GG.F204	UC204	0,57	20	64	86
–	<b>UCF204-12</b>	GG.F204	UC204-12	0,58	19,05	64	86
<b>UCF205</b>	–	GG.F205	UC205	0,85	25	70	95
–	<b>UCF205-16</b>	GG.F205	UC205-16	0,84	25,4	70	95
<b>UCF206</b>	–	GG.F206	UC206	1,11	30	83	108
–	<b>UCF206-18</b>	GG.F206	UC206-18	1,13	28,575	83	108
<b>UCF207</b>	–	GG.F207	UC207	1,5	35	92	117
–	<b>UCF207-20</b>	GG.F207	UC207-20	1,55	31,75	92	117
<b>UCF208</b>	–	GG.F208	UC208	1,91	40	102	130
–	<b>UCF208-24</b>	GG.F208	UC208-24	1,95	38,1	102	130
<b>UCF209</b>	–	GG.F209	UC209	2,3	45	105	137
–	<b>UCF209-28</b>	GG.F209	UC209-28	2,32	44,45	105	137
<b>UCF210</b>	–	GG.F210	UC210	2,56	50	111	143
–	<b>UCF210-30</b>	GG.F210	UC210-30	2,63	47,625	111	143
<b>UCF211</b>	–	GG.F211	UC211	3,31	55	130	163
–	<b>UCF211-32</b>	GG.F211	UC211-32	3,46	50,8	130	163
<b>UCF212</b>	–	GG.F212	UC212	4,25	60	141	175
–	<b>UCF212-36</b>	GG.F212	UC212-36	4,1	57,15	141	175

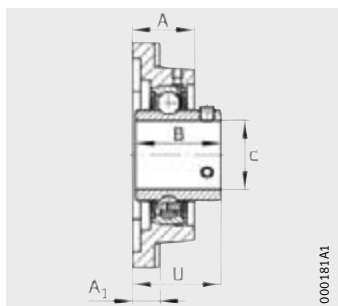

UCF

000181A1

						Basic load ratings	
A	A <sub>1</sub>	N	B	U	Q	dyn. C <sub>r</sub> N	stat. C <sub>r</sub> N
25,5	12	12	31	33,3	M6	12 800	6 600
25,5	12	12	31	33,3	M6	12 800	6 600
27	14	12	34,1	35,8	M6	14 000	7 800
27	14	12	34,1	35,8	M6	14 000	7 800
31	14	12	38,1	40,2	M6	19 500	11 300
31	14	12	38,1	40,2	M6	19 500	11 300
34	16	14	42,9	44,4	M6	25 500	15 300
34	16	14	42,9	44,4	M6	25 500	15 300
36	16	16	49,2	51,2	M6	32 500	19 800
36	16	16	49,2	51,2	M6	32 500	19 800
38	18	16	49,2	52,2	M6	32 500	20 400
38	18	16	49,2	52,2	M6	32 500	20 400
40	18	16	51,6	54,6	M6	35 000	23 200
40	18	16	51,6	54,6	M6	35 000	23 200
43	20	19	55,6	58,4	M6	43 500	29 000
43	20	19	55,6	58,4	M6	43 500	29 000
48	20	19	65,1	68,7	M6	52 000	36 000
48	20	19	65,1	68,7	M6	52 000	36 000